



[Browse Product Range >](#)

Westfield Fasteners Product Specification:

DIN 7972 - Slotted Countersunk Self Tapping Screws

This product guide contains the specification for slotted countersunk self tapping screws, a range of standard parts available from Westfield Fasteners. The basis of this specification is the DIN standard DIN 7972.

Product Description

Traditional slotted countersunk self tapping screws, for use with a countersunk hole forming a flush fitting. Self tapping screws cut their own thread into pre-drilled untapped holes and are commonly used for joining sheet metals, plastics and wood. For use with a flat head screwdriver.

There are many different types of screw that could be defined as 'self tapping', including several more modern designs. The self tapping screws defined here are the long established type adhering to DIN 7972. The same thread forms with differing head types are defined in other standards. These self tapping screws are manufactured in gauge sizes, from number 2 up to number 14, but these sizes are usually stated alongside the millimetre equivalent.

Scope of the DIN Standard.

DIN 7972 is the standard for countersunk head tapping screws driven with a slot. The dimensions, tolerances and characteristics of these type of screws are for sizes from 2.2mm or No.2 to 6.3mm or No.14 inclusively. DIN 7972 covers steel and stainless steel variants.

Self tapping screw thread forms have historically been classified in a number of different ways, and can cause some confusion. The DIN 7972 standard defines the thread form featuring spaced threads and a cone or pointed tip that we are concerned with here as a 'Type C'. This thread form is also known as 'Type AB' elsewhere. These type definitions help to differentiate these cone pointed tapping screws from the square ended or dog point 'Type F' (also known as 'Type B' or 'Type BZ', depending on who you ask).

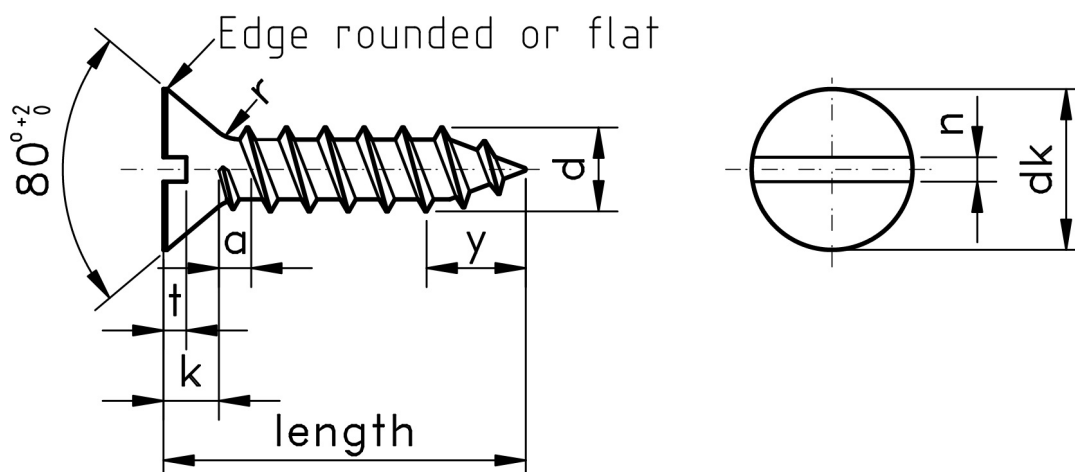

Figure 1: Slotted Countersunk Self Tapping Screws

Table 1: Dimensions & Tolerances according to DIN 7972 (mm)

Thread Size		2.2	2.9	3.5	(3.9)	4.2	4.8	5.5	6.3
p		0.8	1.1	1.3	1.3	1.4	1.6	1.8	1.8
a	max.	0.8	1.1	1.3	1.3	1.4	1.6	1.8	1.8
d _k	max. = nominal size	4.3	5.5	6.8	7.5	8.1	9.5	10.8	12.4
	min.	4	5.2	6.44	7.14	7.74	9.14	10.37	11.97
k	≈	1.3	1.7	2.1	2.3	2.5	3	3.4	3.8
n	Nominal size	0.6	0.8	1	1	1.2	1.2	1.6	1.6
	min.	0.66	0.86	1.06	1.06	1.26	1.26	1.66	1.66
	max.	0.8	1	1.2	1.2	1.51	1.51	1.91	1.91
r	max.	0.8	1.1	1.4	1.5	1.6	1.9	2.1	2.4
t	min.	0.4	0.5	0.6	0.7	0.75	0.85	1	1.2
	max.	0.6	0.75	0.95	1.05	1.15	1.35	1.5	1.75
y max.	Type C	2	2.6	3.2	3.5	3.7	4.3	5	6
	Type F	1.6	2.1	2.5	2.7	2.8	3.2	3.6	3.6

Table 2: Shank Length Tolerances according to DIN 7972 (mm)

Shank Length	+/- (mm)
6.5	0.8
9.5	0.8
13	0.8
16	0.8
19	0.8
22	0.8
25	0.8
32	1.3
38	1.3

Notes on Usage of Tapping Screws

Table 3 provides a guide for appropriate drill sizes for each thread diameter. This information is provided on the assumption that the screw is of carbon (non stainless) steel. The actual diameter selected will depend on the thickness and strength of the material involved. This is based on information provided in the standard DIN 7975. Appropriate holes for use with stainless steel screws should be established by trial and error.

Table 3: Tapping Screw Drill Size Guide, Use with Metals, according to DIN 7975 (mm)

Screw Thread Size	Drill Size (min.-max.)
2.2 (No.2)	1.7-1.9
2.9 (No.4)	2.2-2.5
3.5 (No.6)	2.6-3.1
3.9 (No.7)	2.9-3.5
4.2 (No.8)	3.1-3.7
4.8 (No.10)	3.6-4.3
5.5 (No.12)	4.2-5.0
6.3 (No.14)	4.9-5.8
8.0	6.3-7.4
9.5	7.5-8.9

For further details, please refer to the DIN standard document for this item. E&OE