

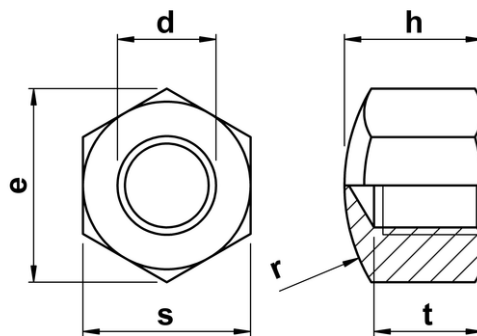

Cap Nuts

A closed end nut often used when a professional attractive finish is called for. Also the cap helps protect the fixture from foreign object ingress/damage and gives a nice smooth snag-free surface. Conforms to DIN 917.



d	thread pitch	h	s	e	r	t min.	t max.
M3	0.50	-	5.5	6.01	-	-	-
M4	0.70	5.5	7	7.66	8	4.16	4.64
M5	0.80	7.0	8	8.79	10	4.96	5.44
M6	1.00	9.0	10	11.05	12	6.71	7.29
M8	1.25	12.0	13	14.38	15	9.21	9.79
M10	1.50	14.0	17	17.77	20	10.65	11.35
M12	1.75	16.0	19	20.03	25	13.15	13.85
M14	2.00	18.0	22	23.35	28	14.65	15.35
M16	2.00	20.0	24	26.75	30	16.65	17.35
M18	2.50	22.0	27	29.56	32	18.58	19.42
M20	2.50	25.0	30	32.95	35	20.58	21.42
M22	2.50	28.0	32	37.29	35	21.58	22.42
M24	3.00	30.0	36	39.55	40	23.58	24.42
M27	3.00	32.0	41	45.20	50	25.58	26.42
M30	3.50	34.0	46	50.85	60	27.58	28.42