



 westfieldfasteners.co.uk
 +44 (0)1844 201133
 enquiries@westfieldfasteners.co.uk

Westfield Fasteners Product Specification:

ISO 10642 - Hexagonal Socket Head Countersunk Screws

This product guide contains the specification for metric threaded socket head countersunk screws as available from Westfield Fasteners. The basis of this specification is the ISO standard ISO 10642, which replaced the original standard DIN 7991. The specification outlined below may include information on sizes and materials that are not covered by the ISO standard but are available.

Product Description

A countersunk headed screw conforming with ISO 10642, requiring a hex key (otherwise known as an Allen key) to fit. The countersunk head is used in conjunction with a countersunk hole to provide a flush, snag free fit. Generally manufactured with a full thread, though occasionally some stock may include a partially threaded shank. The head diameter is slightly larger than that of the equivalent DIN 965 Phillips or Pozi driven screw.

Scope of the ISO standard.

ISO 10642 specifies the tolerances and the permissible variation in form of hexagon socket countersunk head screws, and covers metric thread diameters from M2 up to and including M20. Mechanical properties for these items are defined in ISO 898 and ISO 3506. Table 1 below defines the overall dimensions and tolerances of this screw type. Table 2 defines the tolerances on the shank length. Due to their head design socket countersunk screws are considered to have reduced loadability over other screw types, as defined in ISO 898 and ISO 3506.

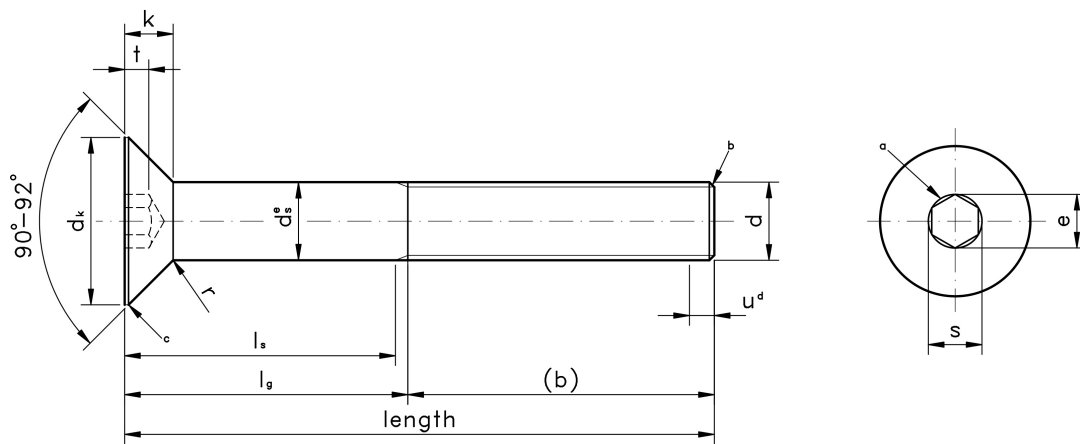

Partially threaded screw

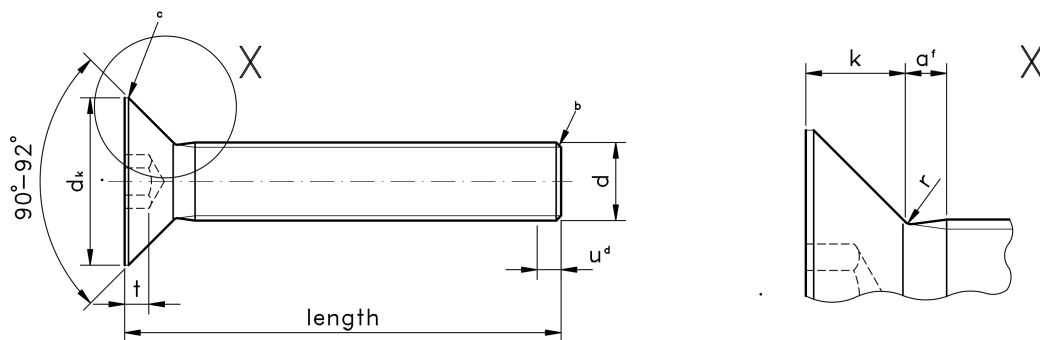

Screw threaded to the head

Figure 1: Socket Head Countersunk Screw

Notes to figure 1:

- a - Slight rounding or countersink at the mouth of the socket may be present.
- b - The threaded end of the bolt can be chamfered or sheared as rolled.
- c - The edge of the head can be flat or rounded.
- d - There may be up to 2 incomplete threads at the end of the bolt.
- e - d_s (shank diameter) only applies where the shank has an unthreaded portion.
- f - Less or the same as 2 threads.

Variations from ISO 10642 / DIN 7991

Manufacturer and/or material markings may be present on the top face of the head.

Table 1: Dimensions & Tolerances according to ISO 10642

Thread, d		M2	M2.5	M3	M4	M5	M6	M8	M10	M12	M14	M16	M20	
p		0.4	0.45	0.5	0.7	0.8	1.0	1.25	1.5	1.75	2.0	2.0	2.5	
b	ref	-	-	18	20	22	24	28	32	36	42	48	60	
d _k	theor max	4.70	5.88	6.72	8.96	11.20	13.44	17.92	22.40	26.88	30.80	33.60	40.32	
	actual	max	4.09	5.08	5.81	7.96	10.07	12.16	16.43	20.69	24.81	28.31	30.61	36.75
min		3.70	4.80	5.54	7.53	9.43	11.34	15.24	19.22	23.12	26.52	29.01	35.40	
d _s	max	2.00	2.50	3.00	4.00	5.00	6.00	8.00	10.00	12.00	14.00	16.00	20.00	
	min	1.86	2.36	2.86	3.82	4.82	5.82	7.78	9.78	11.73	13.73	15.73	19.67	
e	min	1.454	1.733	2.303	2.873	3.443	4.583	5.723	6.863	9.149	11.429	11.429	13.716	
k	ref	max	1.350	1.690	1.860	2.480	3.100	3.720	4.960	6.200	7.440	8.400	8.800	10.160
		min	1.130	1.408	1.522	2.121	2.669	3.218	4.366	5.563	6.711	7.588	7.874	9.037
r	min	0.1	0.1	0.1	0.2	0.2	0.25	0.4	0.4	0.6	0.6	0.6	0.8	
s	nom	1.3	1.5	2	2.5	3	4	5	6	8	10	10	12	
	max	1.360	1.560	2.080	2.580	3.080	4.095	5.140	6.140	8.175	10.175	10.175	12.212	
	min	1.320	1.520	2.020	2.520	3.020	4.020	5.020	6.020	8.025	10.025	10.025	12.032	
t	max	0.85	1.15	1.25	1.65	2.00	2.50	3.20	3.90	4.90	5.10	5.40	6.40	
	min	0.75	1.00	1.10	1.40	1.75	2.20	2.90	3.50	4.30	4.50	4.80	5.60	

Table 2: Shank Length Tolerance according to ISO 10642

mm	+/-
5-6	0.24
8-10	0.29
12-16	0.35
20-30	0.42
35-50	0.5
55-80	0.6
90-110	0.7

For further details, please refer to the ISO/DIN standard document for this item.