



Westfield Fasteners Product Specification:

Pozi Countersunk Head Screws (type Z recess), to DIN 965

This product guide contains the specification for metric threaded pozi countersunk head screws as available from Westfield Fasteners. The basis of this specification is the DIN standard DIN 965.

Product Description

A popular machine screw with a pozi drive (type Z). The countersunk head is usually used in conjunction with a countersunk hole providing a flush, snag free fit. Typically found on consumer electronics and other small machinery where high torque fasteners are not necessary.

Scope of the DIN 965 standard.

The DIN 965 standard specifies the tolerances and the variation in form of pozi countersunk head screws, and covers metric thread diameters for sizes M1.6 up to and including M10. The DIN 965 standard covers both pozi (type Z) and phillips (type H) drives. Table 1 below defines the overall dimensional tolerances of this screw type, and should be used in conjunction with the diagram in figure 1. Table 2 defines the tolerance on the overall length. It should be noted that all lengths stated for countersunk screws are for the overall length, including the head. This is different from other types of screw that have heads designed to sit above the surface of the workpiece. In this case lengths quoted are for the shank length under, but not including the head.

Although the DIN 965 standard has now been superseded by ISO 7046, off the shelf parts are generally still manufactured to the older specification. The ISO standard specifies some revised dimensions and tolerances.

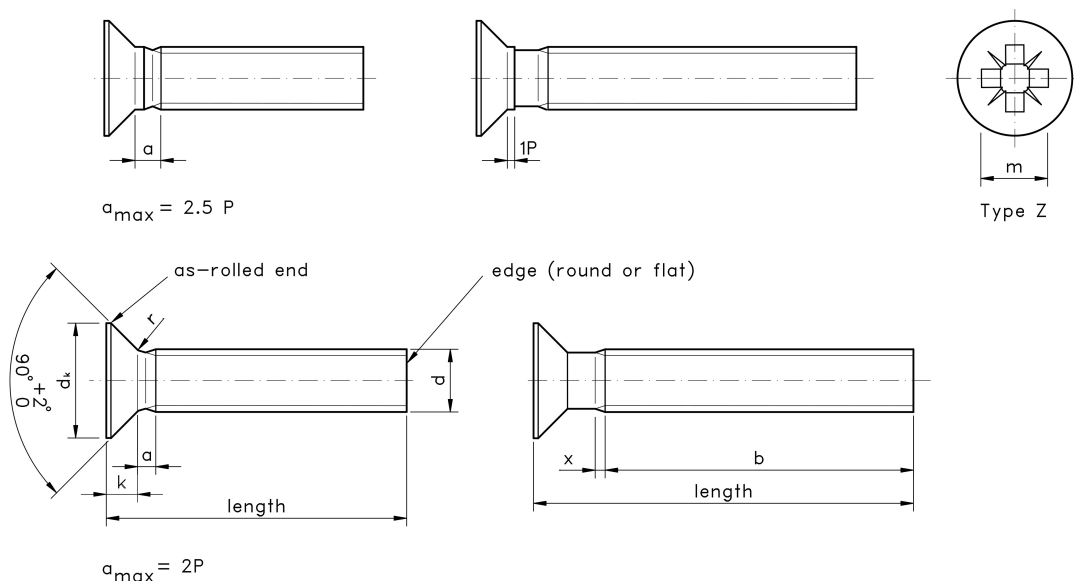

Figure 1: Pozi Countersunk Head Machine Screw

Variations from DIN 965

The DIN standard allows for a partially threaded shank, but off the shelf phillips or pozi countersunk head machine screws are seldom seen with this variation.

Table 1: Dimensional Tolerances according to DIN 965

Thread, d		M2	M2.5	M3	M3.5	M4	M5	M6	M8	M10	
thread pitch (standard metric coarse)	P	0.4	0.45	0.5	0.6	0.7	0.8	1	1.25	1.5	
minimum thread length	b ref.	16	18	19	20	22	25	28	34	40	
head diameter	d _k max. = nominal size	3.8	4.7	5.6	6.5	7.5	9.2	11	14.5	18	
	d _k min.	3.5	4.4	5.3	6.14	7.14	8.84	10.57	14.07	17.57	
head height	k max.	1.2	1.5	1.65	1.93	2.2	2.5	3	4	5	
neck radius	r max.	0.5	0.7	0.8	0.95	1	1.3	1.6	2	2.5	
thread runout	x max.	1	1.1	1.25	1.5	1.75	2	2.5	3.2	3.8	
Recess no.		1			2			3		4	
recess width	m ≈ (approx.)	2.2	2.5	2.8	3.7	4	4.4	6.1	8.5	9.4	
Penetraion depth	min.	0.92	1.22	1.48	1.34	1.6	2.05	2.46	3.86	4.77	
	max.	1.17	1.47	1.73	1.8	2.06	2.51	2.92	4.32	5.23	

Table 2: Shank Length Tolerance according to DIN 965

shank length (mm)	+/- (mm)
3	0.20
4-6	0.25
8-10	0.30
12-16	0.35
20-30	0.40
35-50	0.50
55-60	1.00

For further details, please refer the relevant ISO/DIN standard document for this item.