



 westfieldfasteners.co.uk
 +44 (0)1844 201133
 enquiries@westfieldfasteners.co.uk

Westfield Fasteners Product Specification:

Phillips Pan Head Screws (type H recess), to DIN 7985

This product guide contains the specification for metric threaded phillips pan head screws as available from Westfield Fasteners. The basis of this specification is the DIN standard DIN 7985, but this specification may include information on sizes and materials that are not covered by the DIN standard but are available.

Product Description

A machine screw with a phillips drive, designed to be tightened with a screwdriver. Typically found on consumer electronics and other small machinery where high torque fasteners are not necessary. Sometimes considered more attractive than a pozi drive equivalent.

Scope of the DIN Standard

DIN 7985 specifies the tolerances and the permissible variation in form of phillips pan head machine screws, and covers metric thread diameters from M1.6 to M10 inclusive. The DIN 7985 standard covers both pozi (type Z) and phillips (type H) drives. Table 1 below defines the overall dimensional tolerances of this screw type. Table 2 defines the tolerance on the shank length.

Although the DIN 7985 standard has now been superseded by ISO 7045, off the shelf parts are generally still manufactured to the older specification. The ISO standard specifies slightly smaller head diameters for M3 and M5, and slightly smaller head heights for M2.5, M3.5 and M5.

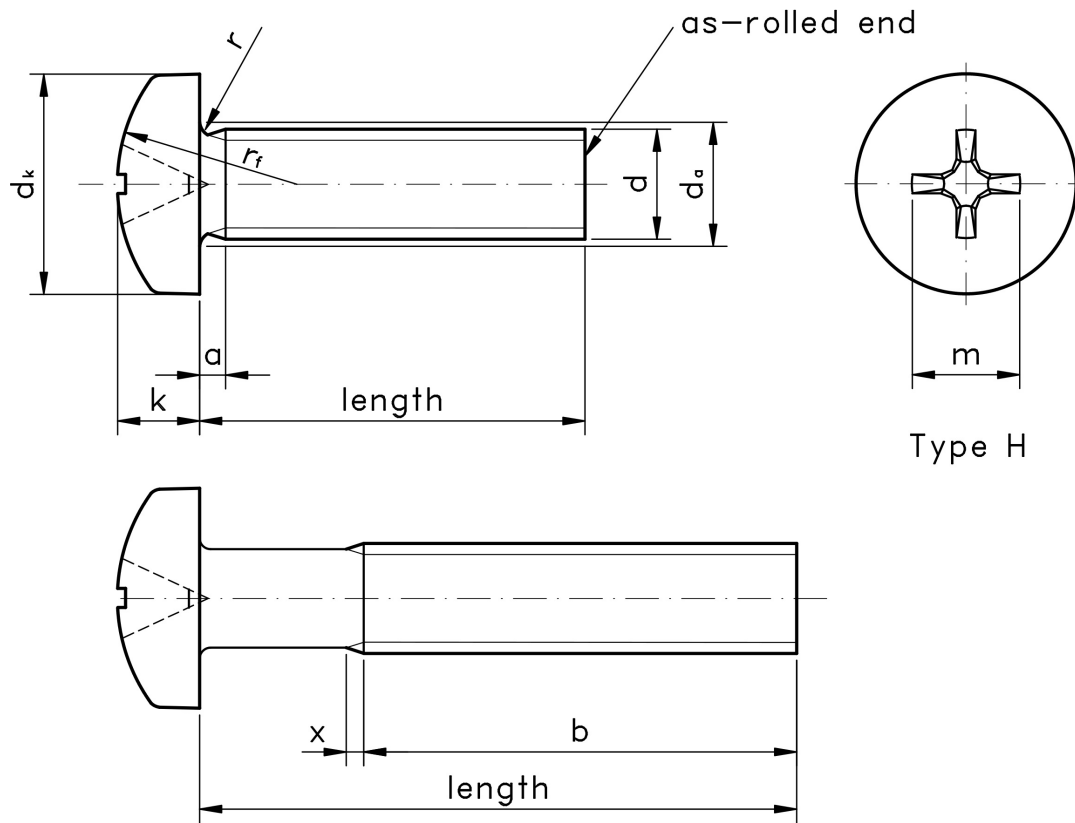

Figure 1: Phillips Pan Head Machine Screw

Variations from DIN 7985

The DIN standard allows for a partially threaded shank, but off the shelf phillips or pozi pan head machine screws are seldom seen with this variation.

Table 1: Dimensions and Tolerances according to DIN 7985

Thread, d			M1.6	M2	M2.5	M3	M3.5	M4	M5	M6	M8	M10
p			0.35	0.4	0.45	0.5	0.6	0.7	0.8	1	1.25	1.5
a	max		0.7	0.8	0.9	1	1.2	1.4	1.6	2	2.5	3
b	min		15	16	18	19	20	22	25	28	34	40
da	max		2.1	2.6	3.1	3.6	4.1	4.7	5.7	6.8	9.2	11.2
dk	nom=max		3.2	4	5	6	7	8	10	12	16	20
	min		2.9	3.7	4.7	5.7	6.64	7.64	9.64	11.57	15.57	19.48
k	nom		1.3	1.6	2	2.4	2.7	3.1	3.8	4.6	6	7.5
	max		1.42	1.72	2.12	2.52	2.82	3.25	3.95	4.75	6.15	7.68
	min		1.18	1.48	1.88	2.28	2.58	2.95	3.65	4.45	5.85	7.32
r	min		0.1	0.1	0.1	0.1	0.2	0.2	0.2	0.25	0.4	0.4
rf	≈		3	4	5	6	7	8	10	12	16	20
x	max		0.8	1.1	1.3	1.6	1.9	2	2.5	3	3.7	4.8
Cross Recess	Recess	no.	0		1		2		3		4	
	m	ref	1.8	2.5	2.7	3.1	4.2	4.6	5.3	6.8	9	10.2
	Type H Penetration	max	1.02	1.4	1.6	2	2.24	2.54	3.27	3.53	4.68	5.88
		min	0.72	1.1	1.3	1.7	1.74	2.04	2.77	3.03	4.18	5.38
	m	ref	1.8	2.4	2.6	3	4	4.3	5	6.7	8.8	9.9
	Type Z Penetration	max	1.17	1.35	1.52	1.93	2.11	2.36	3.1	3.48	4.52	5.69
min		0.92	1.1	1.27	1.68	1.65	1.9	2.64	3.02	4.06	5.23	

Table 2: Shank Length Tolerance according to DIN 7985

Shank Length (mm)	+/- (mm)
3	0.2
4-6	0.24
8-10	0.29
12-16	0.35
20-30	0.42
35-50	0.5
55-60	0.92

For further details, please refer the ISO/DIN standard document for this item.