

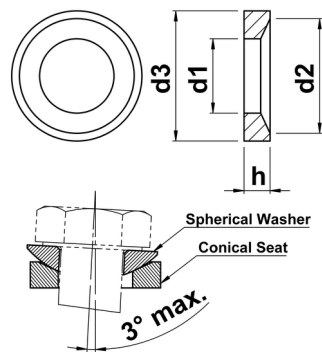

Conical Seat Washers (Type D)

Conical Seat Washers manufactured to DIN 6319 D. Perfect for using in clamping solutions of non parallel surfaces in conjunction with Spherical Washers or hexagon nuts with spherical seating (DIN 6330).



d1	d2	d3	h	for use with
7.1	11.0	12	2.8	M6
9.6	14.5	17	3.5	M8
12.0	18.5	21	4.2	M10
14.2	20.0	24	5.0	M12
19.0	26.0	30	6.2	M16
23.2	31.0	36	7.5	M20