

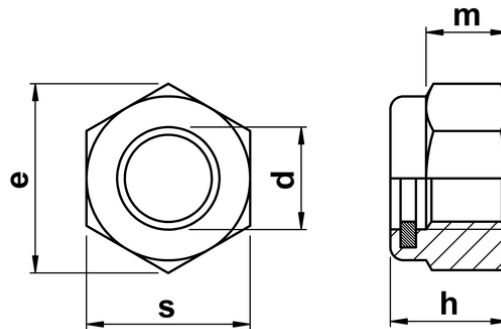

## Thin Nyloc Nuts (Type T)

Prevailing torque type nut manufactured to DIN 985. Popularly employed Hexagon nut incorporating a nylon insert to help prevent loosening when fitted. This is the standard profile variant (Type T), a higher profile option is available under DIN 982 (Type P). Typically fitted with a spanner or ratchet with socket.



d	thread pitch	h max	s max	s min	e min
(M2.5)	0.45	3.80	5.00	-	5.50
M3	0.50	4.00	5.50	5.32	6.01
(M3.5)	0.60	4.50	6.00	-	-
M4	0.70	5.00	7.00	6.78	7.66
M5	0.80	5.00	8.00	7.78	8.79
M6	1.00	6.00	10.00	9.78	11.05
M8	1.25	8.00	13.00	12.73	14.38
M10	1.50	10.00	17.00	16.73	18.90
M12	1.75	12.00	19.00	18.67	21.10
M14	2.00	14.00	22.00	21.67	24.49
M16	2.00	16.00	24.00	23.67	26.75
M18	2.50	18.50	27.00	26.16	29.56
M20	2.50	20.00	30.00	29.16	32.95
M22	2.50	22.00	34.00	-	35.05
M24	3.00	24.00	36.00	35.00	39.55
M27	3.00	27.00	41.00	-	45.02
M30	3.50	30.00	46.00	45.00	50.85
M33	3.50	33.00	50.00	-	55.37
M36	4.00	36.00	55.00	53.80	60.79