

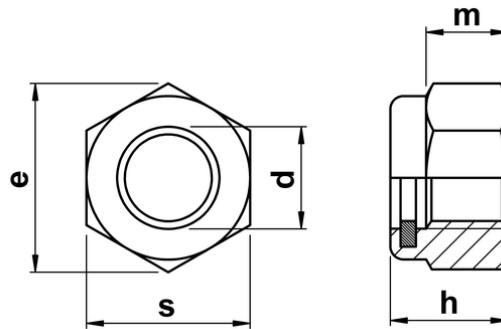

## Thick Nyloc Nuts (Type P) ISO 10512 (DIN 982)

Prevailing torque type nut manufactured to DIN 982. Hexagon nut incorporating a nylon insert to help prevent loosening when fitted. This is the higher profile (Type P) variant with more available thread engagement and is typically fitted with a spanner or ratchet with socket. A lower profile, where perhaps space is at a premium is also available under DIN 985 (Type T).



d	thread pitch	m	h	s	e
<b>M4</b>	0.70	3.60	6.0	7	7.66
<b>M5</b>	0.80	4.40	6.3	8	8.79
<b>M6</b>	1.00	4.90	8.0	10	11.05
<b>M8</b>	1.25	6.44	9.5	13	14.38
<b>M10</b>	1.50	8.04	11.5	17	18.90
<b>M12</b>	1.75	10.37	14.0	19	21.10
<b>M14</b>	2.00	12.10	16.0	22	24.49
<b>M16</b>	2.00	14.10	18.0	24	26.75
<b>M20</b>	2.50	16.90	22.0	30	32.95
<b>M24</b>	3.00	20.20	28.0	36	39.55