

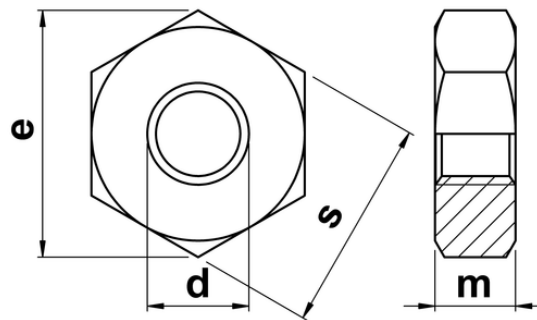

UNC Hex Machine Screw Nuts ASME B18.2.2

Hexagon Machine Screw Nuts (UNC - Unified Coarse Pitch) imported from the USA. These nuts generally have smaller internal diameters than the range available in standard hexagon nuts, so fit the smaller gauge sizes for Imperial screws. They also tend to be thinner or lower in height but have a larger outer diameter. These are specifically designed to be used in conjunction with other UNC screws or bolts. Often used in small electrical goods manufacturing, such as computers and hifi systems.



Thread	tpi	d decimal	s basic	s min.	s max.	e min.	e max.	m min.	m max.
1-64	64	0.073	5/32	0.150	0.156	0.171	0.180	0.043	0.050
2-56	56	0.086	3/16	0.180	0.188	0.205	0.217	0.057	0.066
3-48	48	0.099	3/16	0.180	0.188	0.205	0.217	0.057	0.066
4-40	40	0.112	3/16	0.180	0.188	0.205	0.217	0.057	0.066
4-40	40	0.112	1/4	0.241	0.250	0.275	0.289	0.087	0.098
5-40	40	0.125	5/16	0.302	0.312	0.344	0.361	0.102	0.114
6-32	32	0.138	1/4	0.241	0.250	0.275	0.289	0.087	0.098
6-32	32	0.138	5/16	0.302	0.312	0.344	0.361	0.102	0.114
8-32	32	0.164	1/4	0.241	0.250	0.275	0.289	0.087	0.098
8-32	32	0.164	5/16	0.302	0.312	0.344	0.361	0.102	0.114
8-32	32	0.164	11/32	0.332	0.344	0.378	0.397	0.117	0.130
10-24	24	0.190	11/32	0.332	0.344	0.378	0.397	0.117	0.130
10-24	24	0.190	3/8	0.362	0.375	0.413	0.433	0.117	0.130
12-24	24	0.216	7/16	0.423	0.438	0.482	0.505	0.148	0.161
1/4	20	0.250	7/16	0.423	0.438	0.482	0.505	0.178	0.193
5/16	18	0.312	9/16	0.545	0.562	0.621	0.650	0.208	0.225
3/8	16	0.375	5/8	0.607	0.625	0.692	0.722	0.239	0.257