

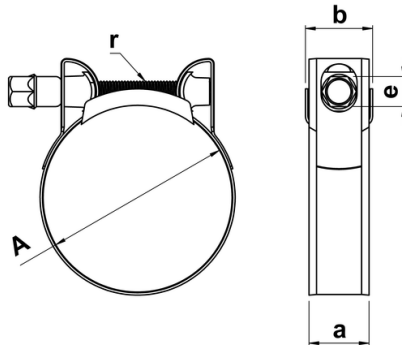

Mikalor Supra Hose Clamps W2

For highly stressed applications heavy duty hose clamps are the preferred alternative to the traditional worm driven hose clip. The unique design of the Mikalor Supra heavy duty hose clamp ensures an even clamping pressure around the entire circumference of the hose clamp making them ideal for securing highly pressurised hoses or pipes, that function at high temperatures such as exhaust pipes and coolant or turbo hoses. The ingenious Mikalor "flip open front" allows easy fitment to pipes and hoses without overly stressing the clamp during assembly. The Mikalor Supra Hose Clamp W2 is a part stainless type with a stainless steel band and high tensile steel zinc plated drive bolt. A lower cost alternative to the fully stainless clamp, suitable for automotive applications.



A (mm)	r	e	a	b	Max. Torque (Nm)	Max. Pressure (Bars)
17 - 19	M6	8	18 (+02)	20	10	45
19 - 21	M6	8	18 (+02)	19.8	10	45
21 - 23	M6	8	18 (+02)	20	10	45
23 - 25	M6	8	18 (+02)	19.8	10	45
25 - 27	M6	8	18 (+02)	20	10	45
27 - 29	M6	8	18 (+02)	19.8	10	45
29 - 31	M7	10	20 (+03)	22	13	40
31 - 34	M7	10	20 (+03)	22	13	40
34 - 37	M7	10	20 (+03)	22	13	40
37 - 40	M7	10	20 (+03)	22	13	40
40 - 43	M7	10	20 (+03)	22	13	40
43 - 47	M7	10	20 (+03)	22	16	36
47 - 51	M7	10	20 (+03)	22	16	36
51 - 55	M7	10	20 (+03)	22	16	36
55 - 59	M7	10	20 (+03)	22	16	36

A (mm)	r	e	a	b	Max. Torque (Nm)	Max. Pressure (Bars)
59 - 63	M7	10	20 (+03)	22	16	36
63 - 68	M7	10	20 (+03)	22	16	36
68 - 73	M8	13	25 (+04)	27.5	30	28
73 - 79	M8	13	25 (+04)	28	30	28
79 - 85	M8	13	25 (+04)	27.5	30	28
85 - 91	M8	13	25 (+04)	27.5	30	20
91 - 97	M8	13	25 (+04)	27.5	30	20
97 - 104	M8	13	25 (+04)	27.5	30	20
104 - 112	M8	13	25 (+04)	27.5	30	12
112 - 121	M8	13	25 (+04)	27.5	30	12
121 - 130	M8	13	25 (+04)	27.5	30	12
130 - 140	M10	13	25 (+04)	31	45	9
140 - 150	M10	13	25 (+04)	31	45	9
150 - 162	M10	15	28 (+04)	31	45	9
162 - 174	M10	15	28 (+04)	31	45	6
174 - 187	M10	15	28 (+04)	31	45	6
187 - 200	M10	15	28 (+04)	31	45	6
200 - 213	M10	15	28 (+04)	31	45	3
213 - 226	M10	15	28 (+04)	31	45	3
226 - 239	M10	15	28 (+04)	31	45	3
239 - 252	M10	15	28 (+04)	31	45	3
252 - 265	M10	15	28 (+04)	31	45	3
265 - 278	M10	15	28 (+04)	31	45	3
278 - 291	M10	15	28 (+04)	31	45	3
291 - 304	M10	15	28 (+04)	31	45	3
304 - 317	M10	15	28 (+04)	31	45	3
317 - 330	M10	15	28 (+04)	31	45	3
330 - 343	M10	15	28 (+04)	31	45	3
343 - 356	M10	15	28 (+04)	31	45	3
356 - 369	M10	15	28 (+04)	31	45	3
369 - 382	M10	15	28 (+04)	31	45	3
382 - 395	M10	15	28 (+04)	31	45	3
395 - 408	M10	15	28 (+04)	31	45	3